

## 250V 10A 7+⊕

### Inserts

Crimp terminal



Insert	Order No.
Male	H-D-07-MC
Female	H-D-07-FC

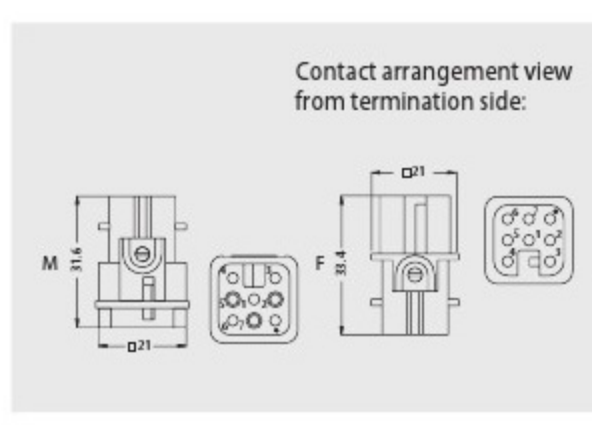

## 250V 10A 8+⊕

### Inserts

Crimp terminal



Insert	Order No.
Male	H-D-08-MC
Female	H-D-08-FC

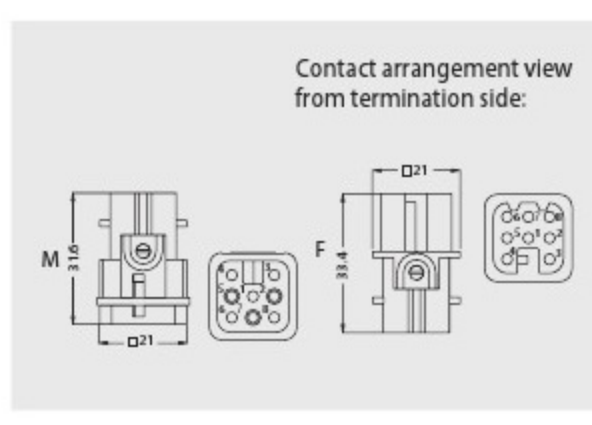

## 250V 10A 15+⊕

### Inserts

Crimp terminal



Insert	Order No.
Male	H-D-15-MC
Female	H-D-15-FC

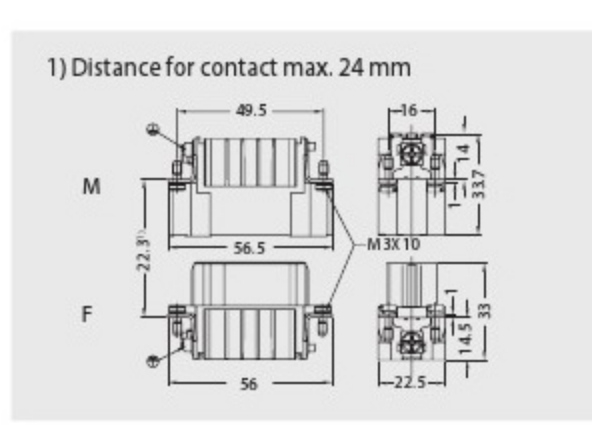

## 250V 10A 25+⊕

### Inserts

Crimp terminal



Insert	Order No.
Male	H-D-25-MC
Female	H-D-25-FC

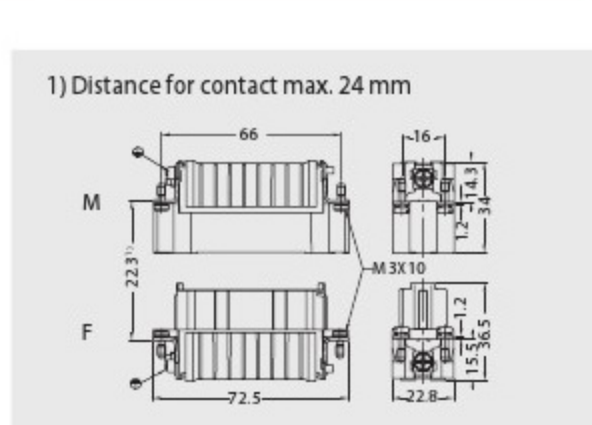

## 250V 10A 50+⊕

### Inserts

Crimp terminal



Insert	Order No.
Male	H-D-25-MC
	H-D-25-MCN (26-50)
Female	H-D-25-FC
	H-D-25-FCN (26-50)

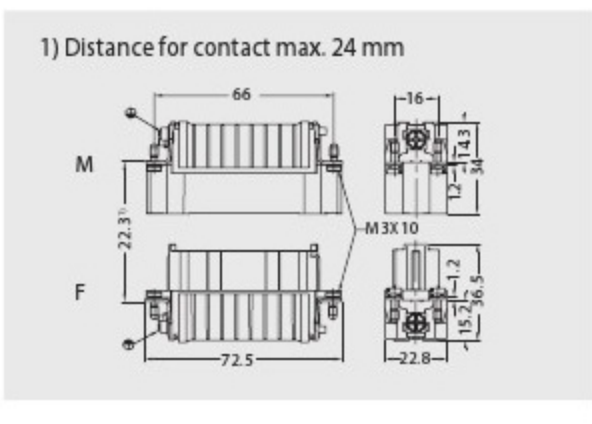

## 250V 10A 40+⊕

### Inserts

Crimp terminal



Insert	Order No.
Male	H-D-40-MC
Female	H-D-40-FC

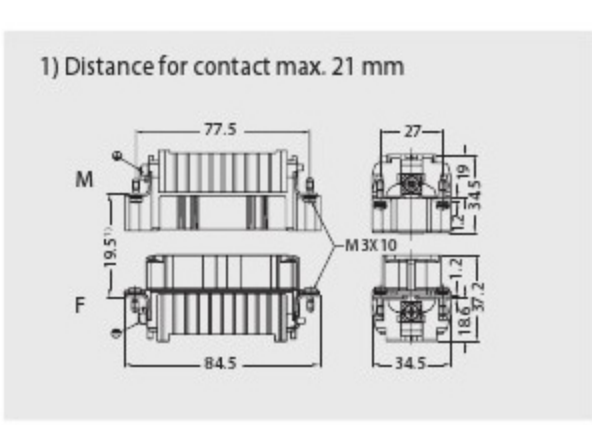

## 250V 10A 64+⊕

### Inserts

Crimp terminal



Insert	Order No.
Male	H-D-64-MC
Female	H-D-64-FC

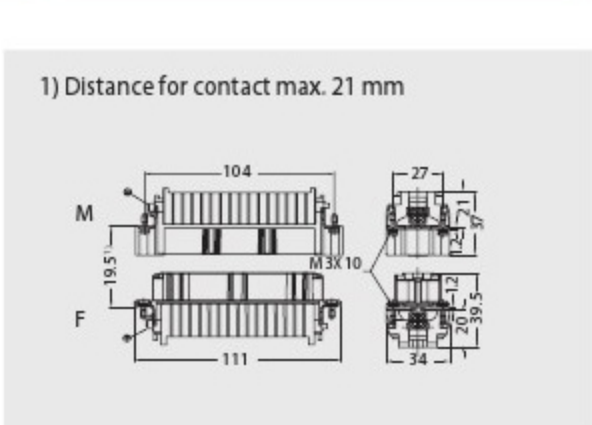

## 250V 10A 80+⊕

### Inserts

Crimp terminal



Insert	Order No.
Male	H-D-40-MC
	H-D-40-MCN (41-80)
Female	H-D-40-FC
	H-D-40-FCN (41-80)

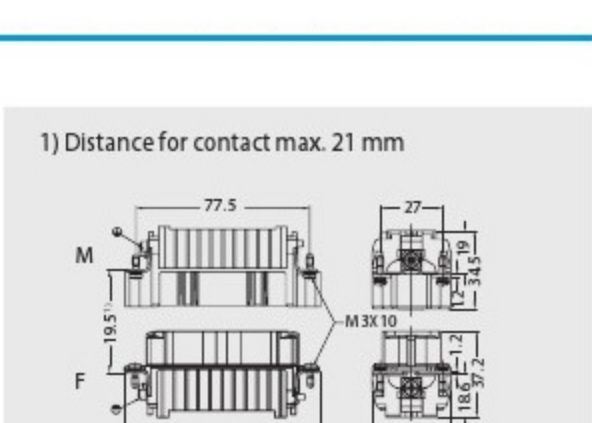

## 250V 10A 128+⊕

### Inserts

Crimp terminal



Insert	Order No.
Male	H-D-64-MC
	H-D-64-MCN (65-128)
Female	H-D-64-FC
	H-D-64-FCN (65-128)

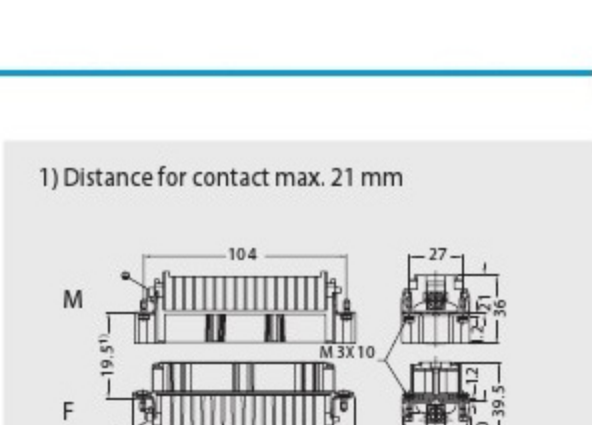

## 250V 10A 24+⊕

### Inserts

Crimp terminal



Insert	Order No.
Male	H-DD-24-MC
Female	H-DD-24-FC

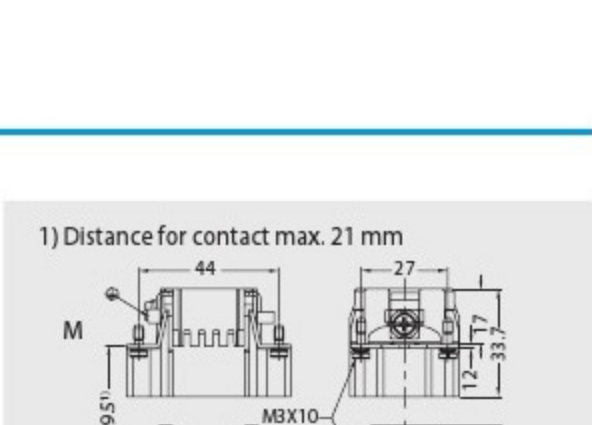

## 250V 10A 42+⊕

### Inserts

Crimp terminal



Insert	Order No.
Male	H-DD-42-MC
Female	H-DD-42-FC

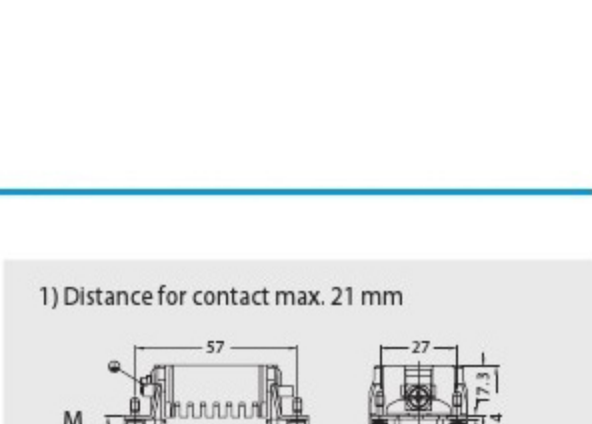

## 250V 10A 72+⊕

### Inserts

Crimp terminal

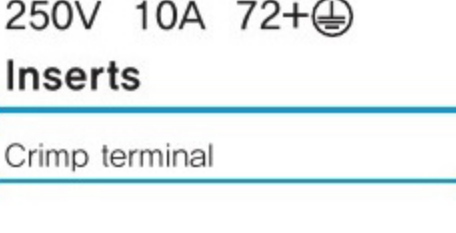

Insert	Order No.
Male	H-DD-72-MC
Female	H-DD-72-FC

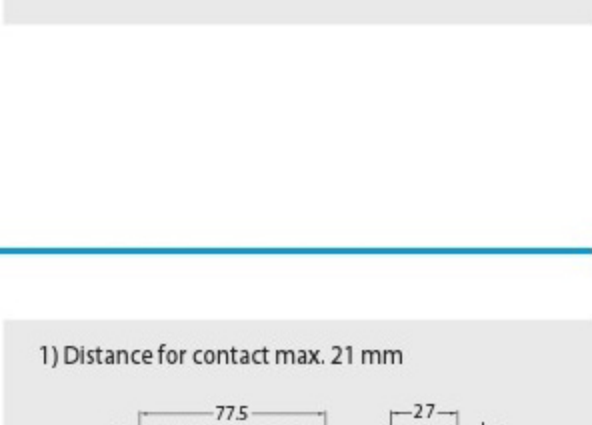

## 250V 10A 108+⊕

### Inserts

Crimp terminal

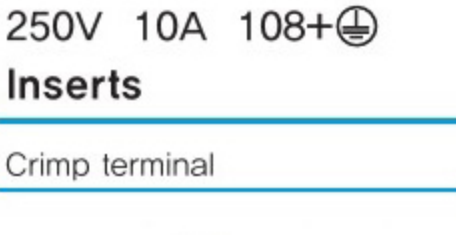

Insert	Order No.
Male	H-DD-108-MC
Female	H-DD-108-FC

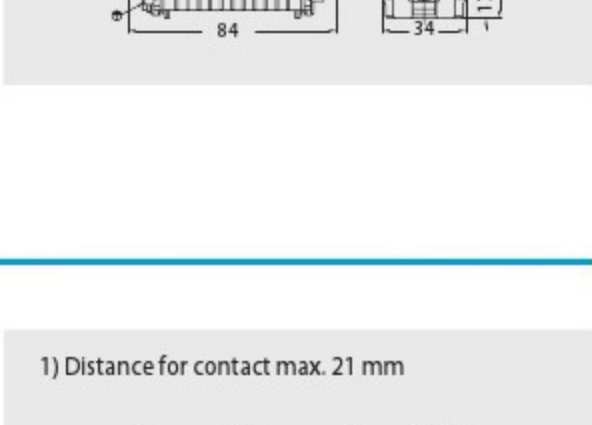

## 250V 10A 144+⊕

### Inserts

Crimp terminal



Insert	Order No.
Male	H-DD-72-MC
	H-DD-72-MCN (73-144)
Female	H-DD-72-FC
	H-DD-72-FCN (73-144)

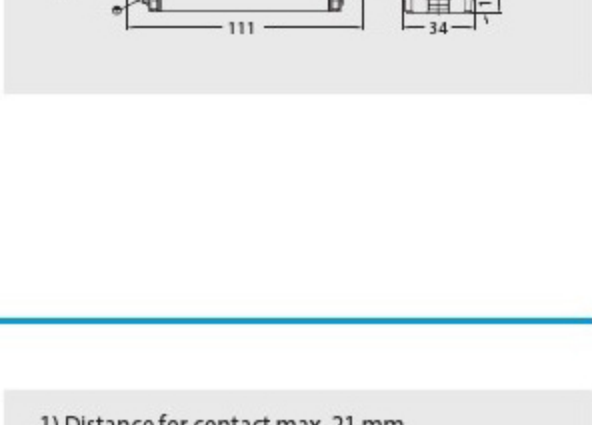

## 250V 10A 216+⊕

### Inserts

Crimp terminal

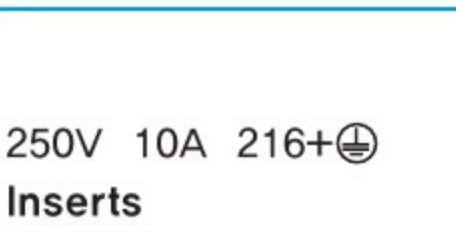

Insert	Order No.
Male	H-DD-108-MC
	H-DD-108-MCN (109-216)
Female	H-DD-108-FC
	H-DD-108-FCN (109-216)

